

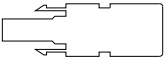



# Configuration JuCon ES2-Plug 1/2

Quantity

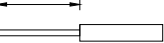
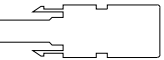

Socket type    
 Plug type    
 mm stripped length 

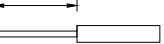
straight cut

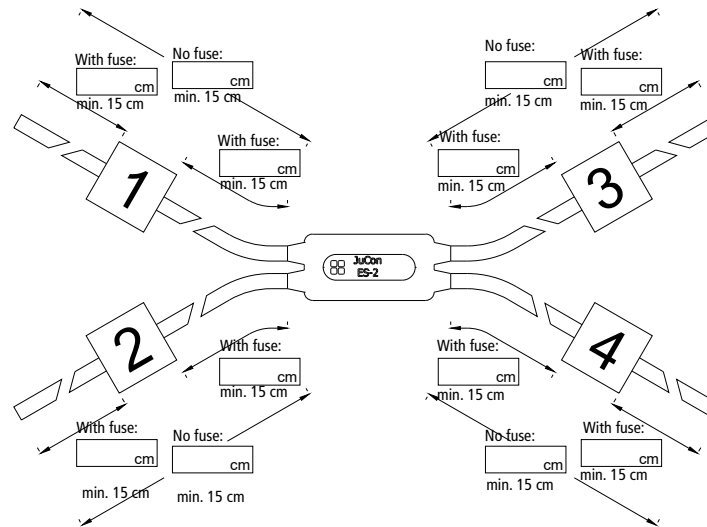

Socket type    
 Plug type    
 mm stripped length 

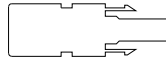
straight cut

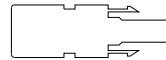

Socket type    
 Plug type    
 mm stripped length   mm

straight cut

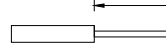
Socket type    
 Plug type    
 mm stripped length   mm

straight cut

Pos.# (1,2,3 or 4):

1    2    3    4

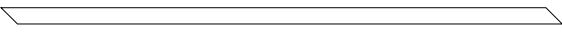
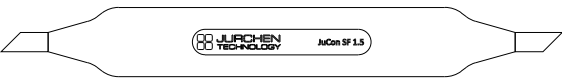
<input type="checkbox"/>		only PV-cable	<input type="checkbox"/>	<input type="checkbox"/>	<input type="checkbox"/>	<input type="checkbox"/>
<input type="checkbox"/>		In-line fuse JuCon SF 1.5	<input type="checkbox"/>	<input type="checkbox"/>	<input type="checkbox"/>	<input type="checkbox"/>

**Configuration example:**

ES2 with no fuse at #1, #2, #4 and a 1500V fuse at #3:

<input checked="" type="checkbox"/>	<input checked="" type="checkbox"/>	<input type="checkbox"/>	<input checked="" type="checkbox"/>
<input type="checkbox"/>	<input type="checkbox"/>	<input checked="" type="checkbox"/>	<input type="checkbox"/>

## Configuration JuCon ES2-Plug 2/2

Features / Notes:

Customer: \_\_\_\_\_  
Deadline: \_\_\_\_\_  
Project: \_\_\_\_\_  
Specifics: \_\_\_\_\_

FCA factory / Collection by customer  
CIF via sea freight  
DAP



Delivery Address (for CIF or DAP)

Recipient Recipient  
(first & last name): \_\_\_\_\_  
Street name + house number: \_\_\_\_\_  
Post code + town / harbour: \_\_\_\_\_  
Country: \_\_\_\_\_

Project manager  
(or applicant) : \_\_\_\_\_